

Kakati™

Vacuum Pumps & Systems

An ISO 9001:2008 Company

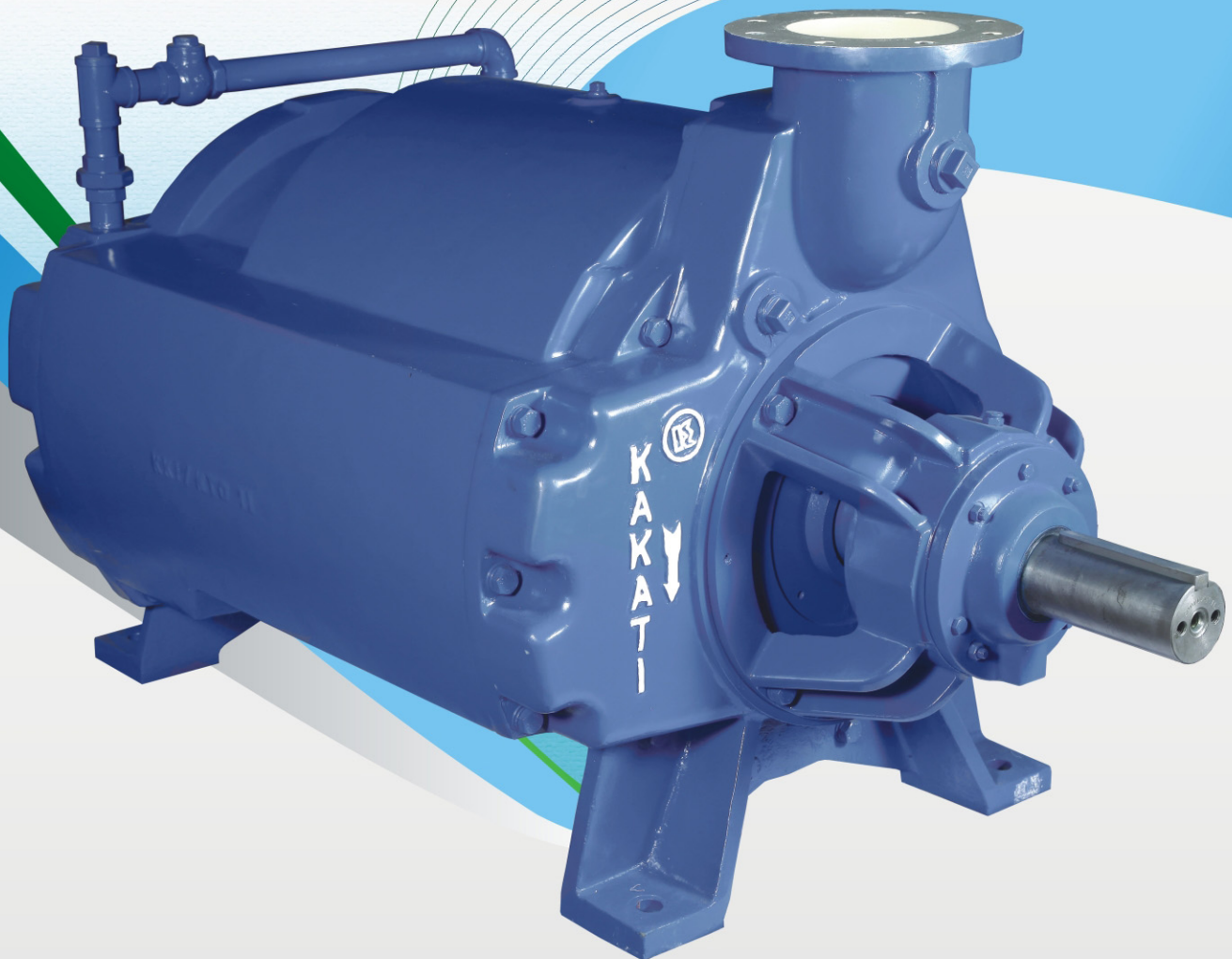

KTS-Series Two Stage Liquid Ring Vacuum Pumps

Kakati Two Stage Liquid Ring Vacuum Pumps

The two stage vacuum pumps are created for high vacuum applications. As the name suggests they have two stages integrated in one pump. They are designed to operate at very low suction pressures. The integral two stage design allows it to condense process vapors and to recover or dispose of them. This results in a highly reliable and efficient vacuum pump. Some of its main applications include condenser evacuation system and black liquor evaporation.



Basic specification

Vacuum range	Upto 740 mmHg
Capacity	Upto 4000 m ³ /hr (2,400 CFM)
Standard Construction material	Cast iron, Stainless Steel

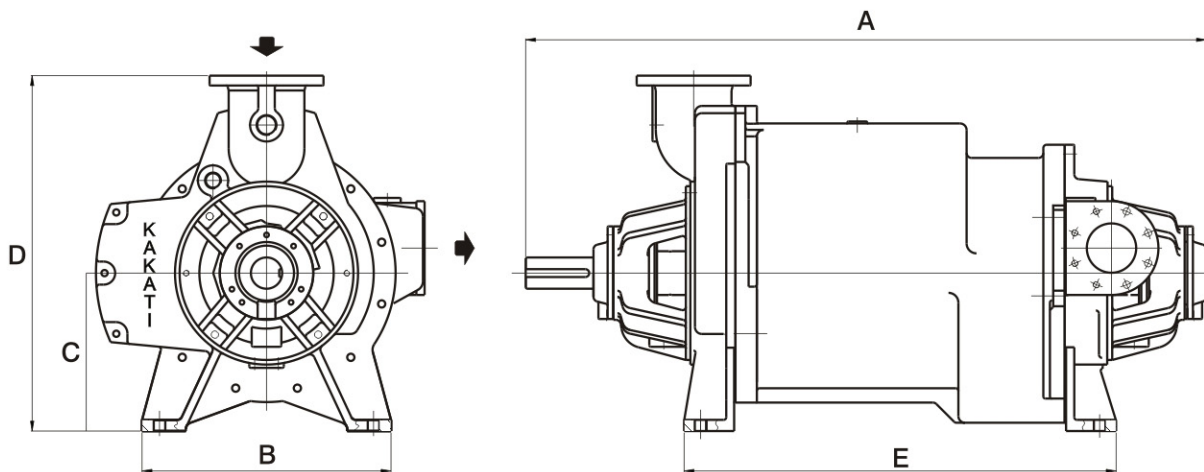

Pump Size	Inlet NB	Outlet NB	A	B	C	D	E
KTS 60	200	150	2070	756	480	1080	1312

Note : All dimensions are in 'mm' & subject to change without notice.



KAKATI KARSHAK INDUSTRIES PRIVATE LIMITED

Manufacturers of Liquid Ring Vacuum Pumps and Systems

Plot No. P-4/1, Road No.1, Nacharam Industrial Area, Hyderabad - 500 076. Telangana, INDIA.

Ph: +91 - 40 - 27153104/05, 27174522/74, 27171298, 27172704, Fax : +91 - 40 - 27171980,

marketing@kakatipumps.com, info@kakatipumps.com

www.kakatipumps.com

www.kakatikarshak.com